

# GPULib

## *GPULib Accelerates Data Analysis Using GPUs*

---

**GPULib** enables engineers, scientists, and analysts, as well as other technical professionals, to speed up their data analysis tasks by leveraging the computing performance available with graphics processing units (GPUs). The increasing amount of data collected by imaging sensors, sophistication of data analysis algorithms, and complexity of numerical models are rapidly outpacing the processing power of CPUs. As an alternative, GPUs offer the necessary processing power for these tasks.

**GPULib**, from Tech-X Corporation, allows GPU users to access high performance computing with minimal modification to their existing programs. By providing bindings for Very High Level Languages (VHLLs), including IDL from ITT Visual Information Solutions, **GPULib** can accelerate new applications or be incorporated into existing applications with minimal effort. No knowledge of massively parallel algorithm development or GPU memory management is required.

---

### **IMAGE FILTERING**

Filter and correlation operations are encountered in many image processing tasks. By performing the filtering operation on GPUs, the overall processing time can be reduced by a factor of 5 to 25 times.

### **ELECTROMAGNETIC WAVE SIMULATION**

Finite-Difference Time-Domain simulations are widely used for the time dependent behavior of electromagnetic fields. By using GPUs, these computations can be accelerated to more than 25 times.

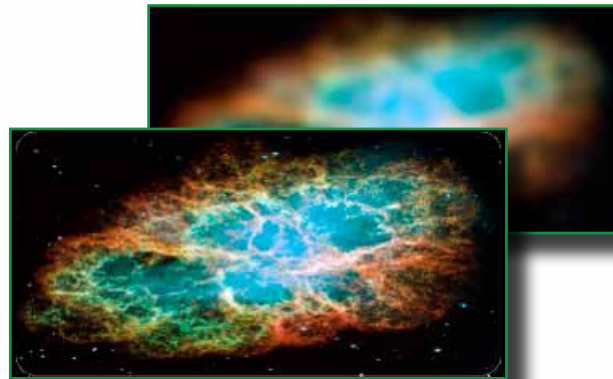
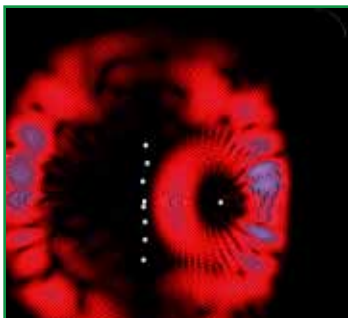

### **ACCELERATE YOUR APPLICATIONS**

GPULib offers accelerated mathematical functions to perform many computations on GPUs in applications such as structural mechanics, fluid dynamics, earth science, biosciences, medial/diagnostic imaging, and financial engineering. Using the GPU accelerated algorithms allows users to achieve speedup compared to their current implementation on a CPU.

### **EASY TO USE**

GPULib seamlessly integrates into the Very High Level Languages, therefore enabling developers to rapidly take advantage of GPUs without having to learn a new programming paradigm.

### POWERFUL

Performing mathematical operations on GPUs can result in 25 – 40 times performance speed improvement when compared to a typical CPU implementation. By offering a large range of functions, from basic arithmetic operations and transcendental functions, to more complex operations like interpolation, correlation, filtering and random number generation, GPULib enables users to execute complex algorithms without forcing them to learn complex parallel programming techniques or GPU-specific data transfer and memory management requirements.

### FLEXIBLE

GPULib has bindings for analysis languages and environments, including IDL. In addition, the C level interface enables use of the GPU functions from lower level languages such as C/C++ and Fortran.

### EXTENSIBLE

The modular architecture of GPULib enables users to extend the library with highly optimized kernels tailored for their particular needs. Tech-X also offers consulting services to help clients realize the potential of GPUs for their specific application.

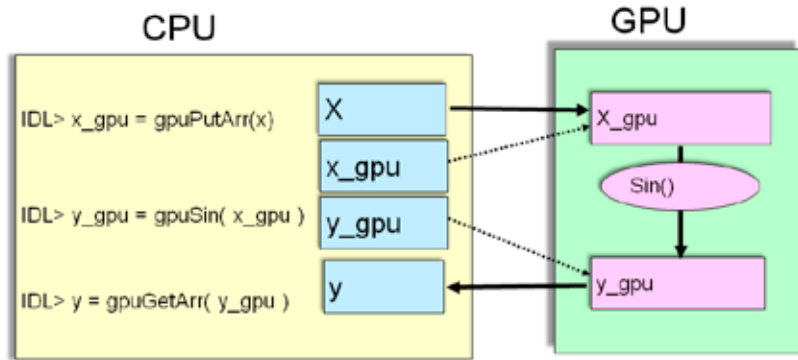

## GPULib's Extensible Architecture

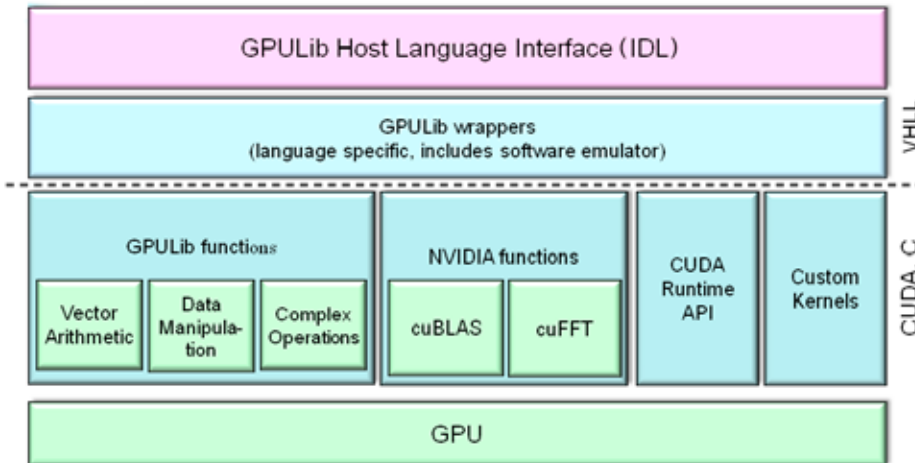

### REFERENCES

CUDA Web Site:  
<http://www.nvidia.com/cuda>  
IDL Web Site:  
<http://www.ittvis.com/idl/>

### ABOUT TECH-X CORPORATION

Tech-X Corporation is committed to technical excellence and innovation. We are dedicated to advances in science and engineering. Our scientists and software engineers address specific research questions and deliver quantifiable results, culminating in specialized skills, advanced technologies, and commercial products that enable large-scale computing solutions and offer a greater understanding of physical processes.

### CONSULTING SERVICES

Tech-X is an NVIDIA partner, offering consulting services to help users develop custom kernels for achieving optimal performance on GPUs for their applications. Our highly trained scientific staff can provide expertise in a broad range of areas related to GPU computing, high-performance computing, numerical methods, and application development.



GPULib and Tech-X are registered trademarks of Tech-X Corporation. All other trademarks are the property of their respective owners.



### TECH-X CORPORATION

5621 ARAPAHOE AVE, SUITE A | BOULDER, CO 80303  
TEL: +1 303 448 0727 | FAX: +1 303 448 7756  
SALES@TXCORP.COM | [HTTP://GPULIB.TXCORP.COM](http://GPULIB.TXCORP.COM)

# GPULib